

İÇTEN PİLOTLU TEK YÖNLÜ DENGE VALFİ

IN LINE, SINGLE ACTING, INTERNALLY PILOTED OVERCENTER VALVES

OWC / SE - ... / L

ÇALIŞMASI / OPERATING

Karşı denge valflerini üzerindeki sıkı nokta kavıtasyonu önlemek için ve pompa çıkışından yük tutmak içindir. Isı koruması sağlar ve ayrıca her hangi bir arıza durumunda yük tutmayı sağlar.

Are overcenter valves with one tight point on hardened steel and are used to prevent cavitation, keeping a load from running ahead of the pump. They provide thermal relief protection and locking the load in cases of hydraulic line breakage or in the event of accidental operation of the directional valve when the pump is turned off.

NOT / NOTE:

İstenilen yükün 1.3 katına ayarlanmalıdır.
Valve should be set at 1.3 times load induced pressure.

Max. Çalışma Basıncı:

$$\frac{350 \text{ bar}}{1.3} = 270 \text{ bar}$$

Standartı alüminyum gövde, çelik gövde isteğe bağlı.
Aluminium body valves as standard, steel body on request.

Valfte 2 çeşit ayar şekli mevcuttur.
The valve is available with 2 types of adjustment.

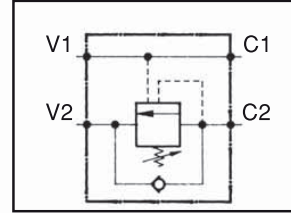
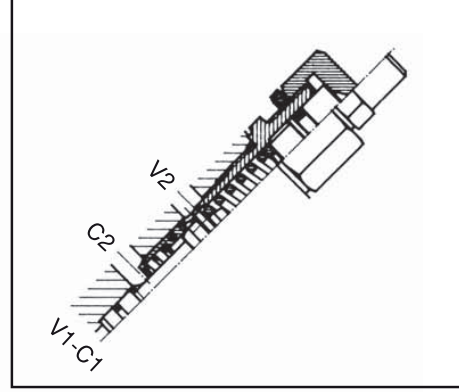
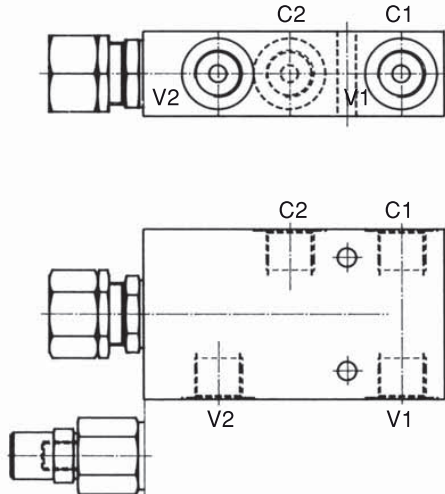

HİDROLİK PERFORMANS HYDRAULIC PERFORMANCE

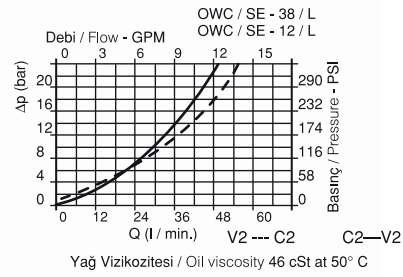
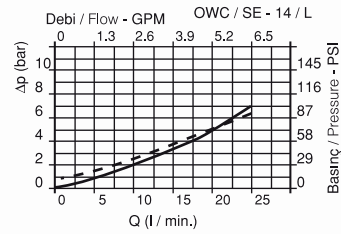

PERFORMANS / PERFORMANCE

Max. basınç ayarı Max. setting pressure	350 bar 5000 PSI
Pilot oranı Pilot ratio	4.25 : 1
Yağ sıcaklığı Oil temperature	°C -30 +80
Filtrasyon Filtration	micron 30

İÇTEN PİLOTLU TEK YÖNLÜ DENGE VALFİ

IN LINE, SINGLE ACTING, INTERNALLY PILOTED OVERCENTER VALVES

GENEL ,ÖL ÇÜ ,DEVRE ÖRNEĞİ

OVERALL, DIMENSIONS, TYPICAL CIRCUIT EXAMPLE

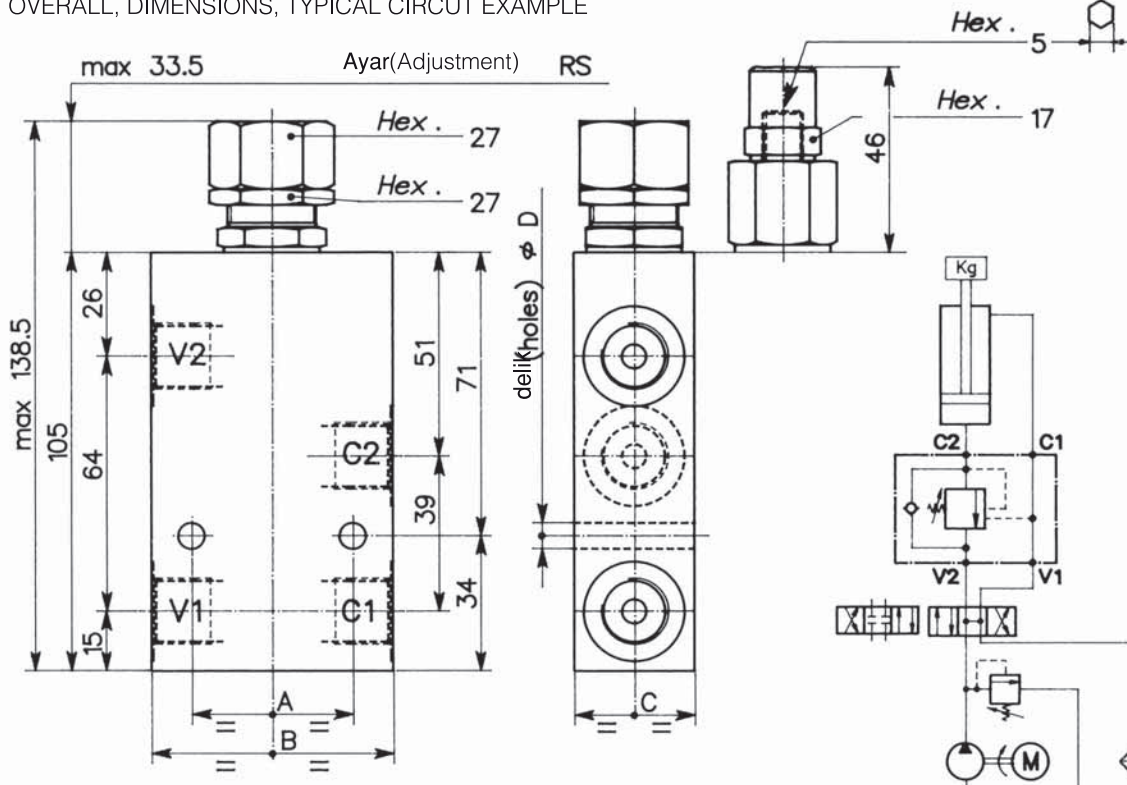

VALF KODU VALVE CODE	A	B	C	D	Bağlantı ölçüsü Port Size V2-C2-V1-C1 GAS (BSPP)	Nominal Ölçü Rated Size DN	Maks. Debi Max. Flow Rate l/min-GPM
OWC / SE - 14/L-...	40	60	30	6.5	1/4"	6	25-6.5
OWC / SE - 38/L-...					3/8"	8	40-10
OWC / SE - 12/L-...	50	70	35	8.5	1/2"	10	60-15

VALF KODU VALVE CODE	Ayar Aralığı Setting Range 60 ÷ 350 bar	Ayar Aralığı Setting Range 30 ÷ 220 bar
OWC / SE - 14/L	316	317
OWC / SE - 38/L	003	053
OWC / SE - 12/L	008	058
OWC / SE - 14/L-RS	318	319
OWC / SE - 38/L-RS	150	151
OWC / SE - 12/L-RS	152	153

Debi 5 l/dk. iken Std. Basınç değeri Std. bar setting (made at 5 l/1')	Max. min bar ayar aralığı Setting range min-max bar	Renk Colour
350	60 ÷ 350	Yeşil Green
220	30 ÷ 220	Sarı Yellow

SİPARİŞ KODU / ORDERING CODE

001		000
-----	--	-----

İÇTEN PİLOTLU TEK YÖNLÜ TEK ETKİLİ DENGE VALFİ

IN LINE, SINGLE ACTING, INTERNALLY PILOTED, OVERCENTER VALVES.

A - OWC / SE - ... / L
OWC / SE - ... - L

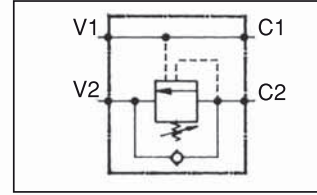
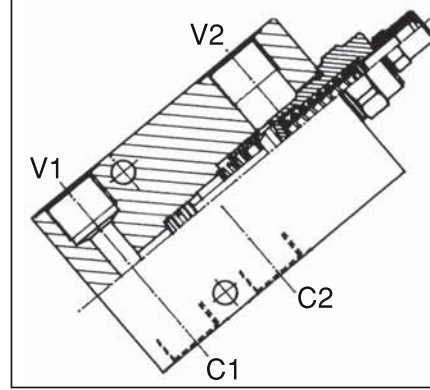

ÇALIŞMASI / OPERATION

Sert çelik kaplı kısmında sıkı bir nokta bulunan denge valfleri kaviteasyonu önlemek içindir, ayrıca ısı koruması vardır, herhangi bir sorun olduğunda ya da bozulma pompadan gelen yükü tutar. İyi bir performans almak için bizim tavsiyemiz açık merkez valf kullanılmasıdır.

Are overcenter valves with one tight point on hardened steel and are used to prevent cavitation, keeping a load from running ahead of the pump. They provide thermal relief protection and locking the load in cases of hydraulic line breakage or in the event of accidental operation of the directional control valve when the pump is turned off. In order to get the best valve operation we suggest to use them with 'open centre' directional controls.

NOT / NOTE:

Valfler çalışma basıncından 1,3 kat daha düşük basınca ayarlanmalıdır.
Valve should be set at 1.3 times load induced pressure.

Max. Çalışma Basıncı: $\frac{350 \text{ bar}}{1.3} = 270 \text{ bar}$
Max. Working Pressure

Alüminyum ya da çelik gövde standarttır.
Standard with aluminium or steel body.

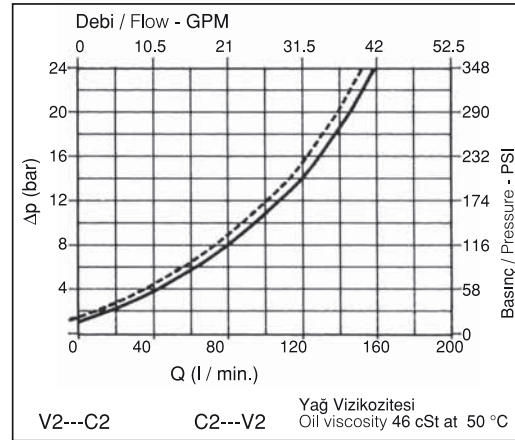

PERFORMANSLAR / PERFORMANCES

Nominal ölçü Rated size	DN	12
Max. debi Max. flow-rate		150 l/min 40 GPM
Max. basınç ayarı Max. setting pressure		350 bar 5075 PSI
Pilot oranı Pilot ratio		6.2 : 1
Yağ sıcaklığı Oil temperature	°C	-30 +80
Filtrasyon Filtration	micron	30 ÷ 50



GENEL, BAĞLANTI ÇÖZÜMLERİ VE TİPİK DEVRE ÖRNEĞİ

GENEL, DIMENSIONS, MOUNTING SOLUTIONS AND TYPICAL CIRCUIT EXAMPLE

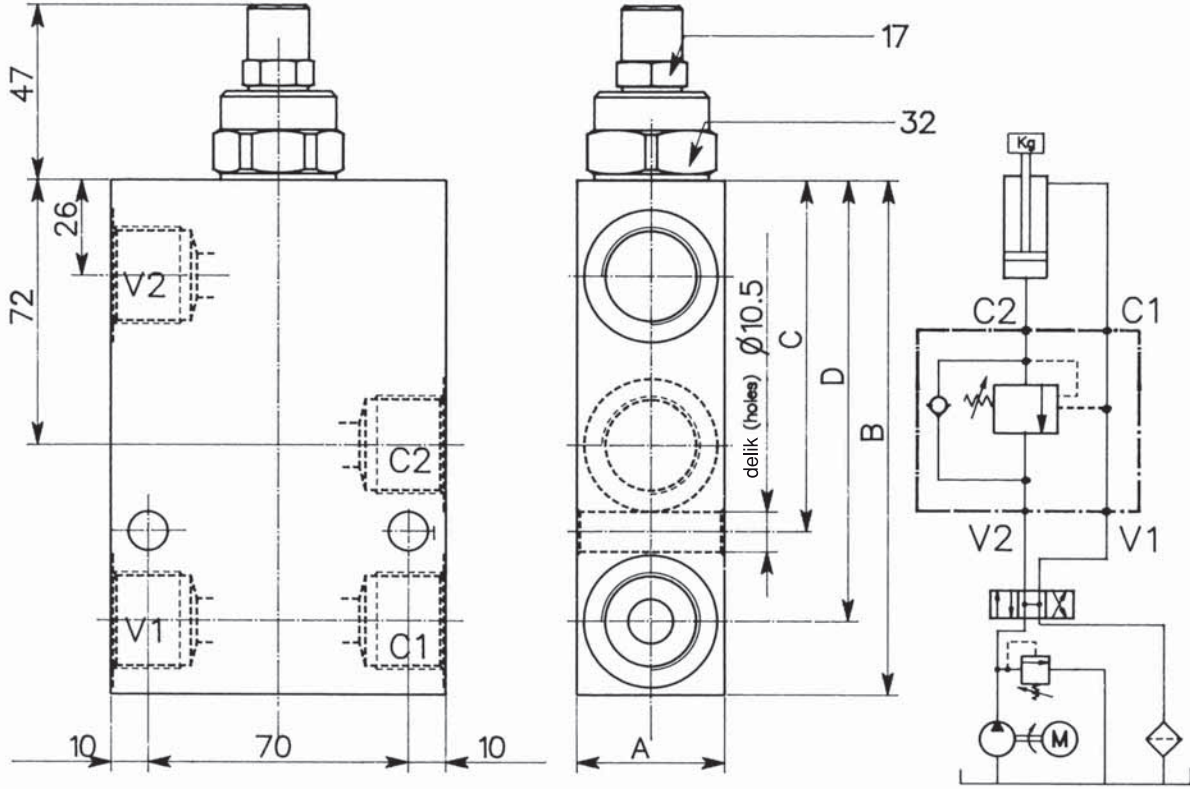

VALF KODU VALVE CODE	Ayar aralığı Setting range 30 ÷ 350 bar	Gövde Body	A	B	C	D	Bağlantı ölçüsü Port size V1-C1 V2-C2 GAS (BSPP)	Nominal Ölçü Rated size DN	Maks. debi Max. flow rate l / min - GPM
A-OWC/SE-34/L	265	Çelik Steel	40	140	95	120	3/4"	12	120-31
OWC/SE-34/L	219	Alüminyum Aluminium							
A-OWC/SE-100/L	266	Çelik Steel	50	165	107	142	1"	4	160-42
OWC/SE-100/L	267	Alüminyum Aluminium							

Debi 5 l/dk iken Std. bar setting (made at 5 l/1')	Ayar aralığı Setting range min - max bar	Renk Colour
220	30 ÷ 350	Sarı Yellow

SİPARİŞ KODU / ORDERING CODE

001		000
-----	--	-----



OWC-SE-...-L-CC-..

COUNTERBALANCE VALVE FOR CLOSED CENTRE SPOOL WITH IN LINE BODY

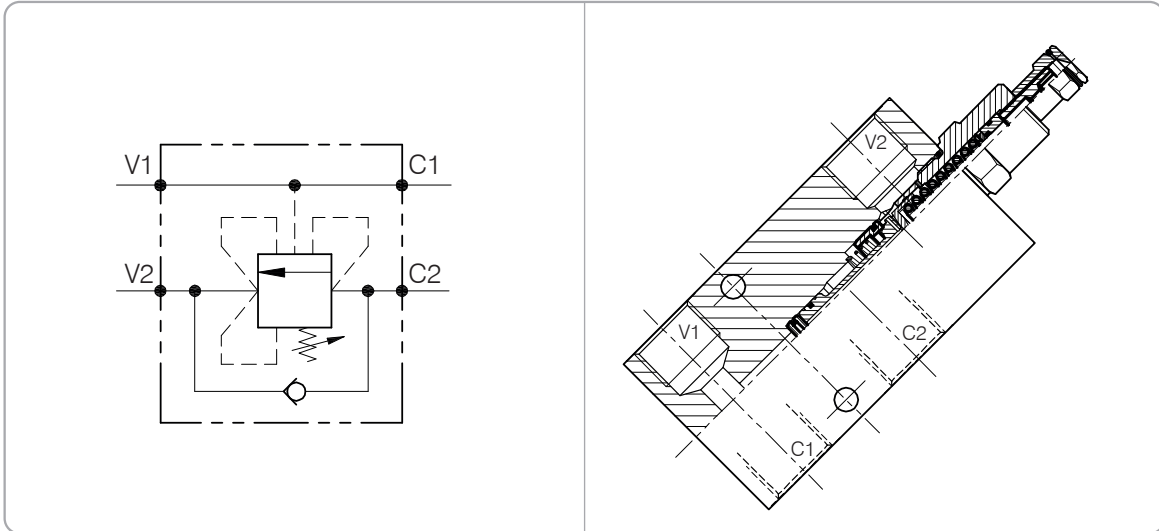

Performance

Rated size	DN 12/14
Min/Max flow-rate	1/160 l/min - 0.26/42.3 GPM
Max peak pressure	450 bar - 6525 PSI
Max setting pressure	350 bar - 5075 PSI
Standard pilot ratio	6.2 : 1
Room temperature	-30°C + 50°C
Oil temperature	-30°C + 80°C
Recommended filtration	30÷50 micron
Tightening torque	
Weight	

Performance Details

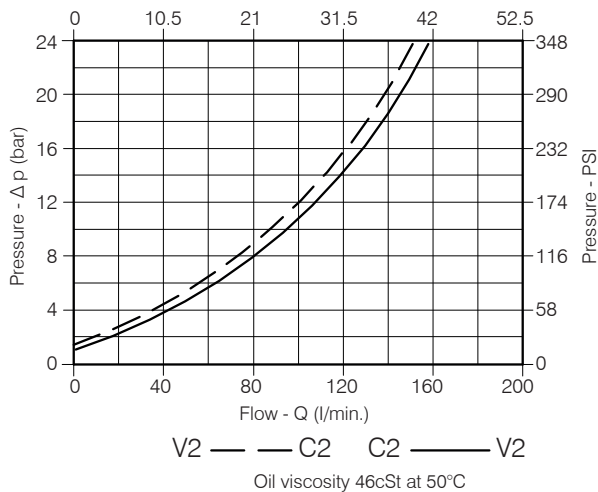

NOTE:

Valve should be set at 1.3 times load induced pressure.

EXAMPLE:

Max working pressure: 350 bar / 1.3 = 270 bar



OWC-SE-...-L-CC-..

Hydraulic valves and integrated components

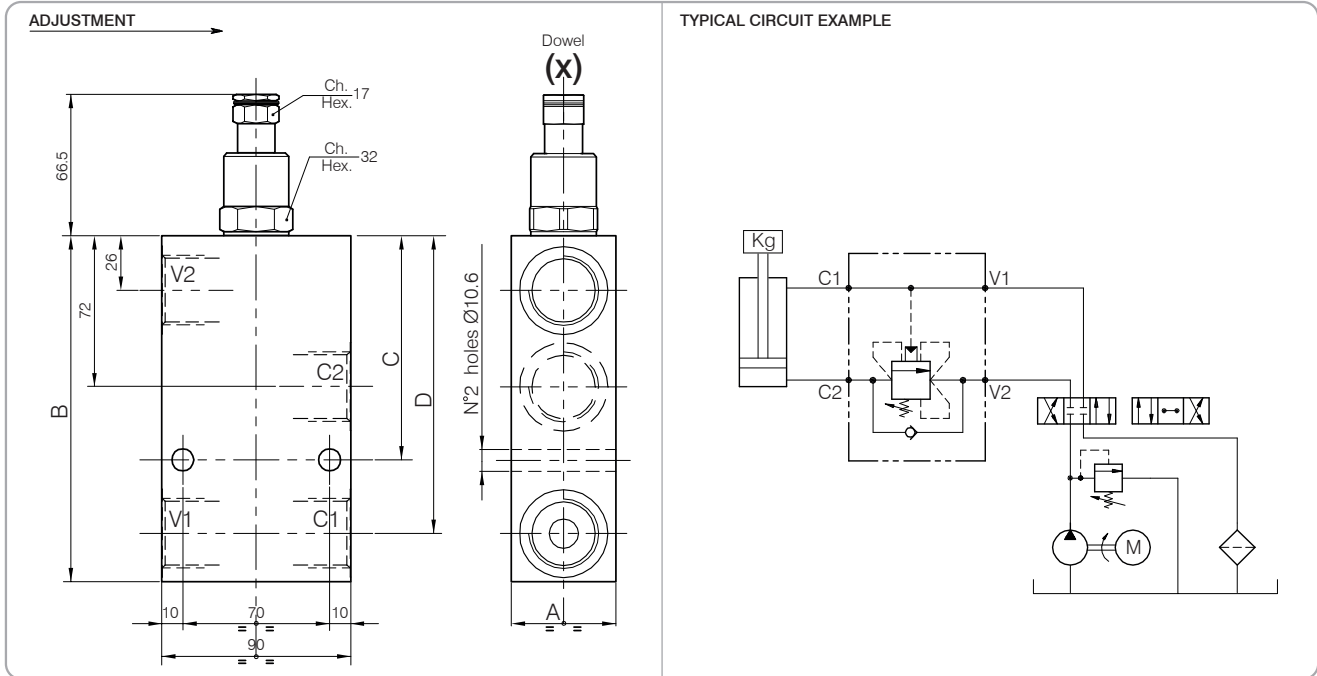

Dimensions

Setting Range	A	B	C	D	Port size	Rated size	Max flow-rate
					V2-C2 GAS (BSPP)	DN	l/min - GPM
468	40	140	95	120	3/4"	12	120-31
469	50	165	107	142	1"	14	160-42

Ordering Code

0 0 1 • 4 6 8 • 0 • X 0 • A

Setting Range	
468	
469	
Setting range 60÷350 bar (yellow spring)	
Std. bar setting Q=5 l/1' 250 bar	Pressure rise - turn of screw (140)

Body
Zinc plated
Steel

Adjustment
Dowel

Pilot Ratios
0 = 6.2 : 1
G = 4.1 : 1